

2.92mm INTERFACE MATING DIMENSIONS

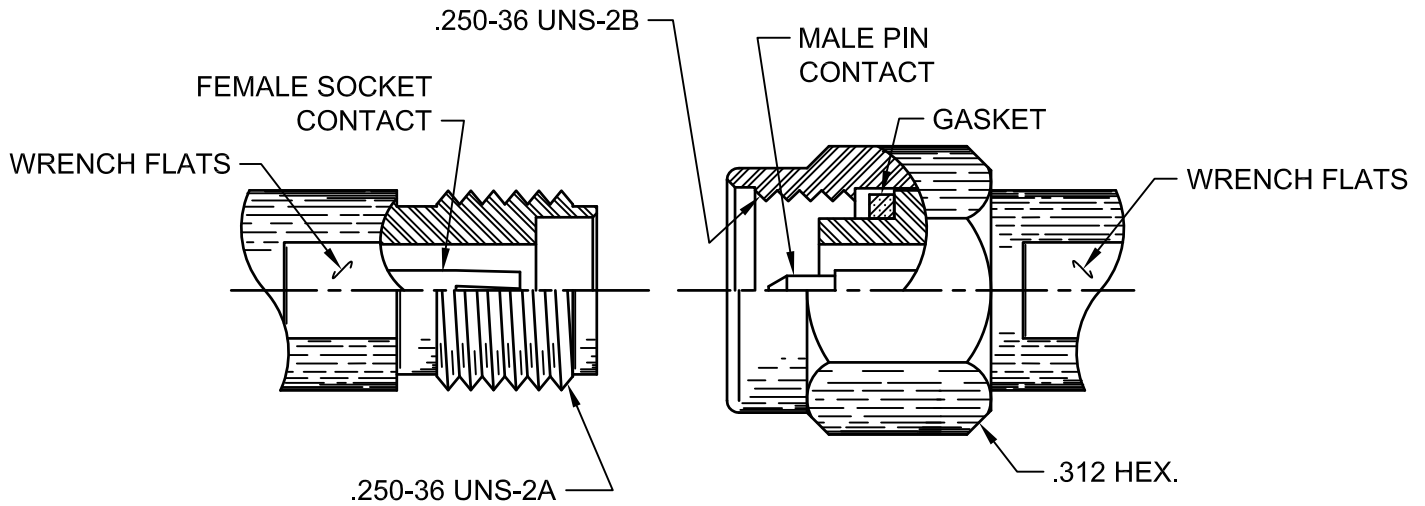

INTERFACE DIMENSIONS

FEMALE / JACK			
LTR.	MAX. INCHES	MIN.	mm
A	.0770	.0750	1.93
B	.0503	.0497	1.27
C	.1153	.1147	2.92
D	.1830	.1810	4.62
E	.2120	.2080	5.33

MALE / PLUG			
LTR.	MAX. INCHES	MIN.	mm
F	.1808	.1783	4.56
G	.1153	.1147	2.92
H	.0365	.0355	0.91
I	.0700	.0600	1.65
J	.0960	.0920	2.39

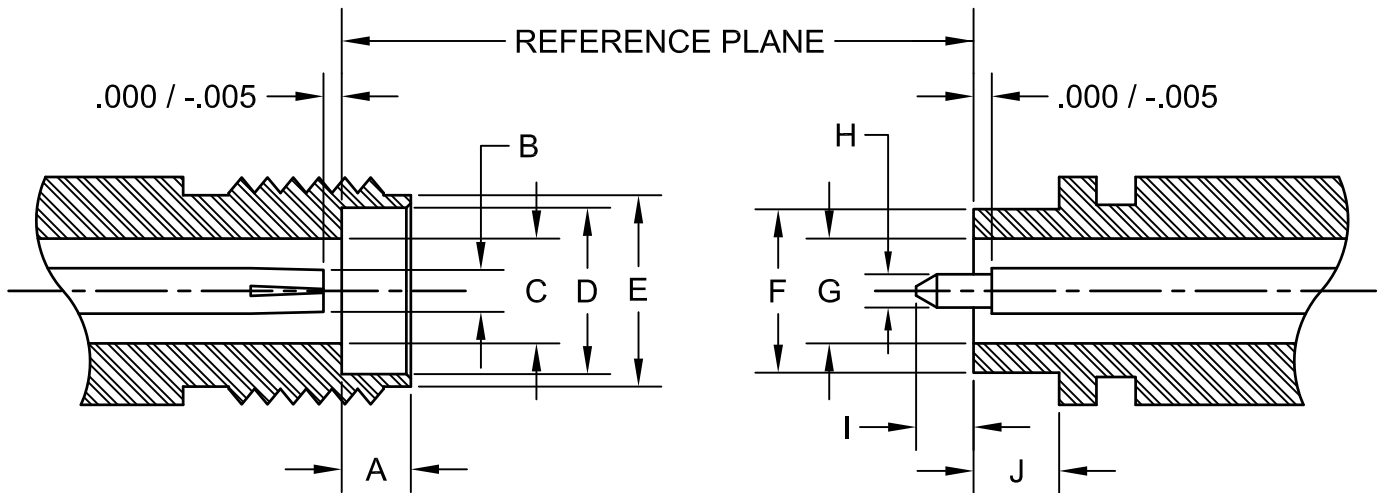

DWG NO. **2.92mm Series**

SGMC MICROWAVE
www.sgmcmicrowave.com

REVISIONS

LTR.	DESCRIPTION: (ECN#)	DATE:
--	DWG. RELEASED	02/04/02

TITLE:
2.92mm INTERFACE MATING DIMENSIONS

Manufacturer of Precision Coaxial Connectors

"PROPRIETARY INFORMATION" THE INFORMATION WITHIN THIS DRAWING IS PROPRIETARY AND SHALL NOT BE USED OR DISCLOSED WITHOUT PRIOR WRITTEN PERMISSION FROM (SGMC) SGMC MICROWAVE.

SCALE: NTS
DRAWN: LRH II
SHEET: 1 OF 1

CAGE CODE: 1UYM4
APPR: *Letta*
SIZE: A