

DWG NO.

100-09-51-000

NOTES:

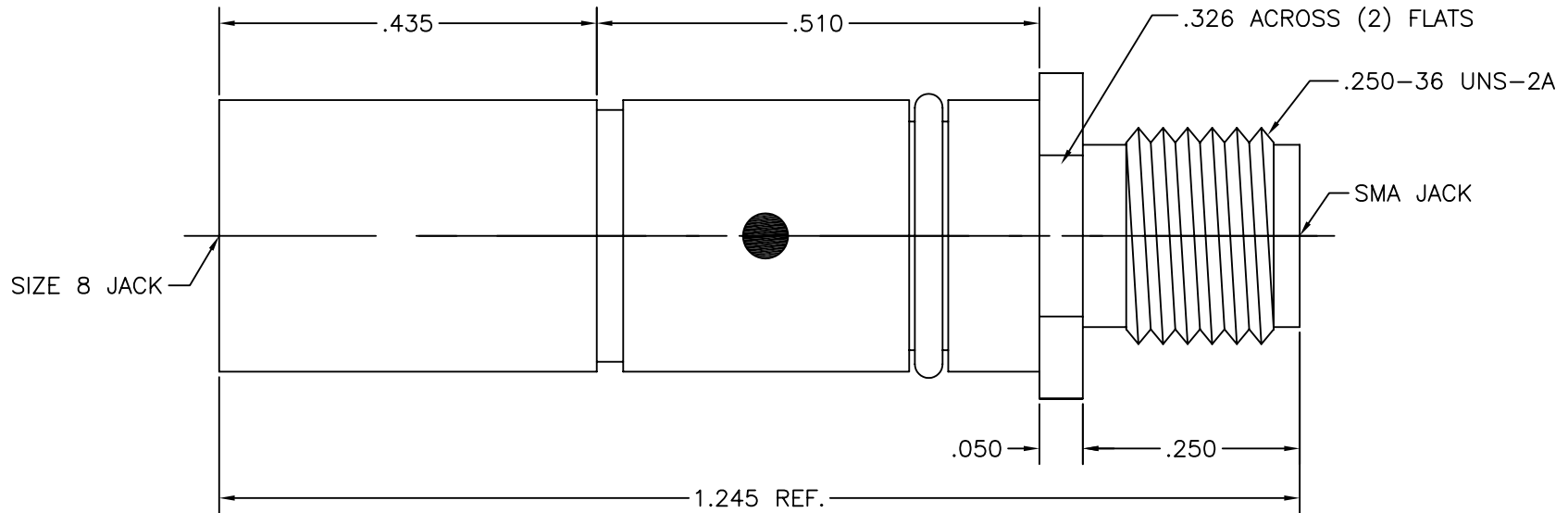

DWG NO.

100-09-51-000

**SGMC MICROWAVE**  
www.sgmcmicrowave.com

USED ON:

**"OUTLINE DRAWING"**

REVISIONS

LTR:	DESCRIPTION: (ECN#)	DATE:
--	DWG. RELEASED	05/09/05

TITLE:

**SIZE 8 FEMALE  
TO SMA FEMALE**

SCALE: NTS

CAGE CODE: 1UYM4

SIZE: A

SHEET: 1 OF 1

DRAWN: LRH II

APPR:

- UNLESS OTHERWISE SPECIFIED:
1. REMOVE ALL BURRS.
  2. ALL DIMENSIONS ARE AFTER PLATING.
  3. BREAK ALL CORNERS & EDGES .005 R. MAX.
  4. CHAMFER 1st & LAST THREADS 45°.
  5. DIAMETERS ON COMMON CENTERS SHALL BE CONCENTRIC WITHIN .002 T.I.R.
  6. ALL SURFACES FINISHED TO 32√.

TOLERANCES  
ALL DIMENSIONS  
ARE IN INCHES  
"DECIMALS"  
.X ±.030  
.XX ±.010  
.XXX ±.005

FINISH:

MATERIAL:

"PROPRIETARY INFORMATION" THE INFORMATION WITHIN THIS DRAWING IS PROPRIETARY AND SHALL NOT BE USED OR DISCLOSED WITHOUT PRIOR WRITTEN PERMISSION FROM (SGMC) SGMC MICROWAVE.