

DWG NO.

100-51-51-000

NOTES:

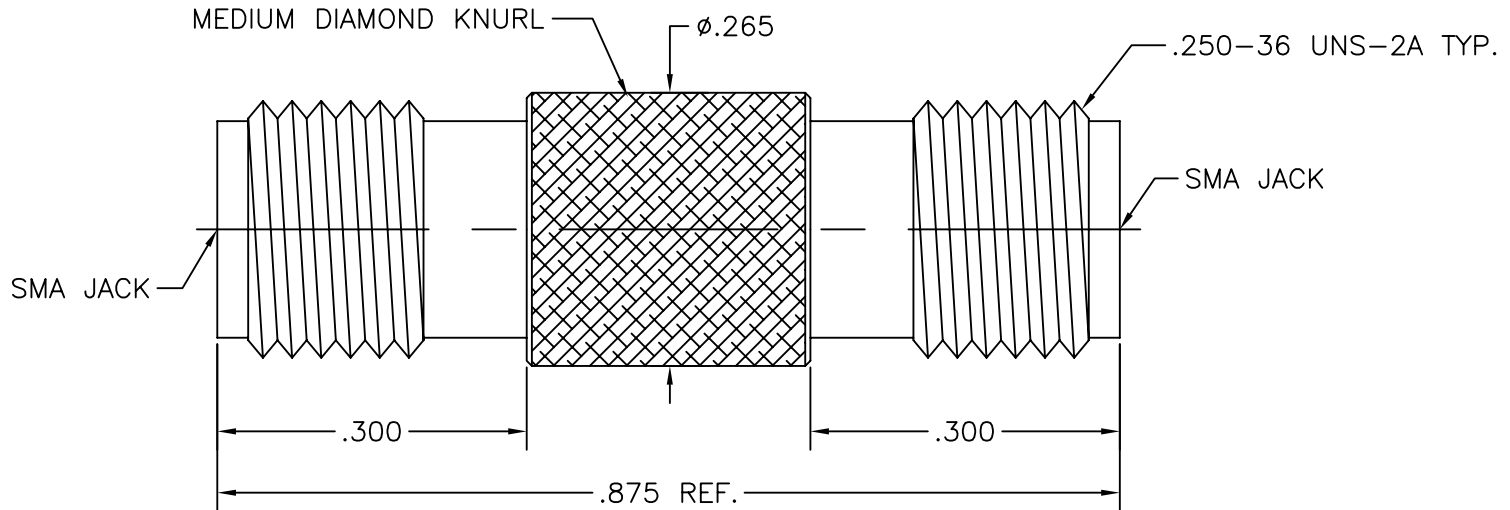

DWG NO.

100-51-51-000

**SGMC MICROWAVE**  
www.sgmcmicrowave.com

USED ON:

**"OUTLINE DRAWING"**

REVISIONS

| LTR: | DESCRIPTION: (ECN#) | DATE:    |
|------|---------------------|----------|
| --   | DWG. RELEASED       | 06/20/01 |

TITLE:

**SMA FEMALE TO  
SMA FEMALE  
(PASSIVATED)**

SCALE: NTS

CAGE CODE: 1UYM4

SIZE: A

SHEET: 1 OF 1

DRAWN: LRH II

APPR:

UNLESS OTHERWISE SPECIFIED:

1. REMOVE ALL BURRS.
2. ALL DIMENSIONS ARE AFTER PLATING.
3. BREAK ALL CORNERS & EDGES .005 R. MAX.
4. CHAMFER 1st & LAST THREADS 45°.
5. DIAMETERS ON COMMON CENTERS SHALL BE CONCENTRIC WITHIN .002 T.I.R.
6. ALL SURFACES FINISHED TO 32V.

TOLERANCES  
ALL DIMENSIONS  
ARE IN INCHES

"DECIMALS"

.X ±.030  
.XX ±.010  
.XXX ±.005

FINISH:

MATERIAL:

"PROPRIETARY INFORMATION" THE INFORMATION WITHIN THIS DRAWING IS PROPRIETARY AND SHALL NOT BE USED OR DISCLOSED WITHOUT PRIOR WRITTEN PERMISSION FROM (SGMC) SGMC MICROWAVE.