

DWG NO.

131-35-35-000

NOTES:

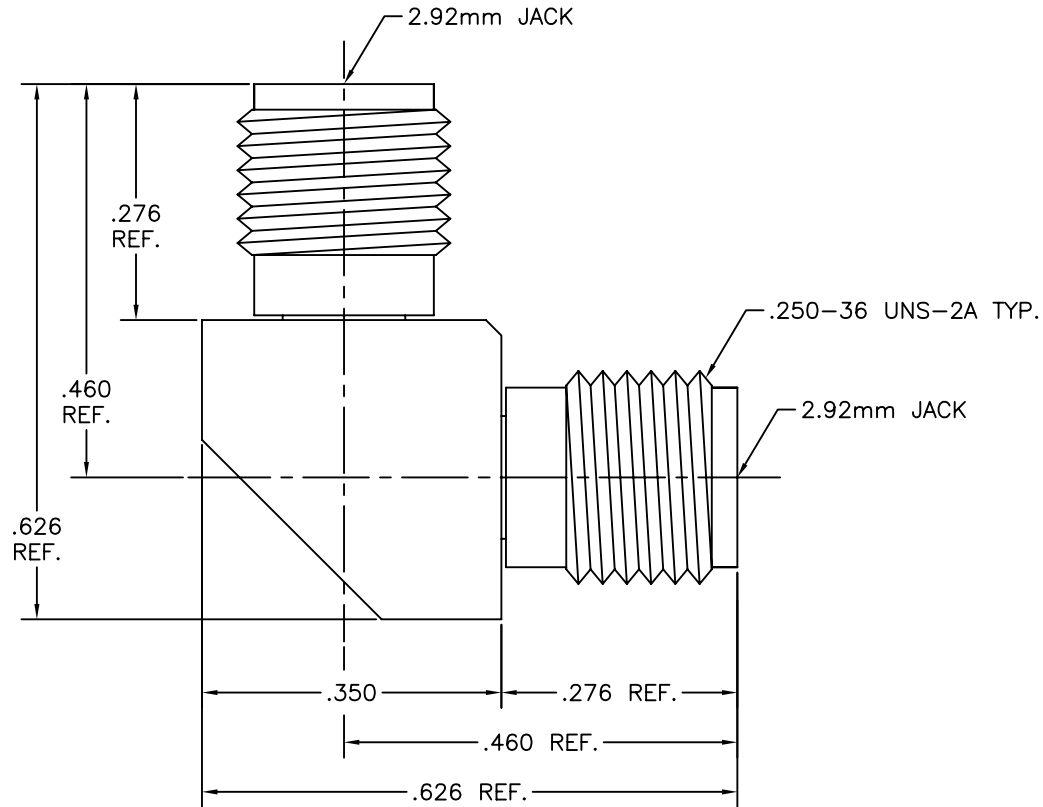

DWG NO. 131-35-35-000

**SGMC MICROWAVE**  
www.sgmcmicrowave.com

USED ON:  
**"OUTLINE DRAWING"**

REVISIONS

TITLE:  
**2.92mm FEMALE TO  
2.92mm FEMALE  
RIGHT ANGLE (90°)**

SCALE: NTS    CAGE CODE: 1UYM4    SIZE: A

SHEET: 1 OF 1    DRAWN: LRH ||    APPR:

LTR:	DESCRIPTION: (ECN#)	DATE:
--	DWG. RELEASED	10/02/01
A	ECN. #1187	07/20/07

- UNLESS OTHERWISE SPECIFIED:
1. REMOVE ALL BURRS.
  2. ALL DIMENSIONS ARE AFTER PLATING.
  3. BREAK ALL CORNERS & EDGES .005 R. MAX.
  4. CHAMFER 1st & LAST THREADS 45°.
  5. DIAMETERS ON COMMON CENTERS SHALL BE CONCENTRIC WITHIN .002 T.I.R.
  6. ALL SURFACES FINISHED TO 32√.

TOLERANCES  
ALL DIMENSIONS  
ARE IN INCHES

"DECIMALS"  
.X ±.030  
.XX ±.010  
.XXX ±.005

FINISH:

MATERIAL:

"PROPRIETARY INFORMATION" THE INFORMATION WITHIN THIS DRAWING IS PROPRIETARY AND SHALL NOT BE USED OR DISCLOSED WITHOUT PRIOR WRITTEN PERMISSION FROM (SGMC) SGMC MICROWAVE.