

DWG NO.

131-51-51-000

NOTES:

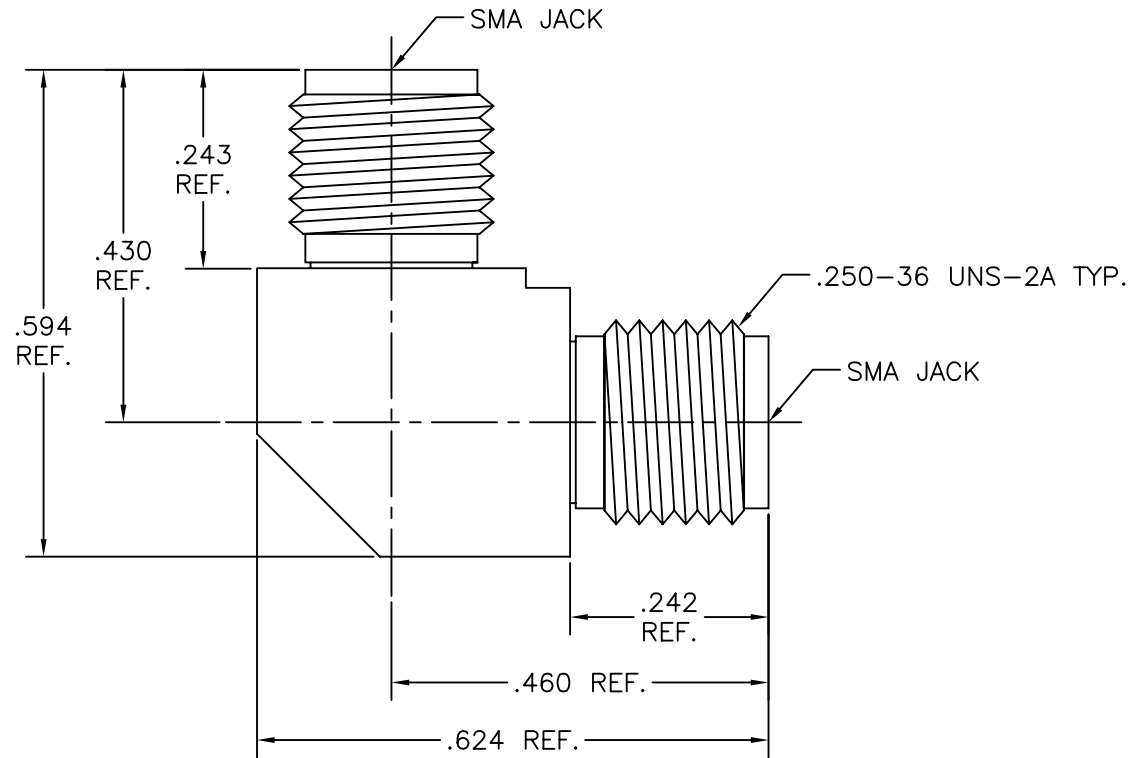

DWG NO.

131-51-51-000

SGMC MICROWAVE
www.sgmcmicrowave.com

USED ON:

"OUTLINE DRAWING"

REVISIONS

LTR:	DESCRIPTION: (ECN#)	DATE:
--	DWG. RELEASED	02/22/02
A	ECN. #1091	02/05/04

TITLE:

**SMA FEMALE TO
SMA FEMALE
RIGHT ANGLE (90°)**

SCALE: NTS

CAGE CODE: 1UYM4

SIZE: A

SHEET: 1 OF 1

DRAWN: LRH II

APPR:

- UNLESS OTHERWISE SPECIFIED:
1. REMOVE ALL BURRS.
 2. ALL DIMENSIONS ARE AFTER PLATING.
 3. BREAK ALL CORNERS & EDGES .005 R. MAX.
 4. CHAMFER 1st & LAST THREADS 45°.
 5. DIAMETERS ON COMMON CENTERS SHALL BE CONCENTRIC WITHIN .002 T.I.R.
 6. ALL SURFACES FINISHED TO 32√.

TOLERANCES
ALL DIMENSIONS
ARE IN INCHES
"DECIMALS"
.X ±.030
.XX ±.010
.XXX ±.005

FINISH:

MATERIAL:

"PROPRIETARY INFORMATION" THE INFORMATION WITHIN THIS DRAWING IS PROPRIETARY AND SHALL NOT BE USED OR DISCLOSED WITHOUT PRIOR WRITTEN PERMISSION FROM (SGMC) SGMC MICROWAVE.