

SGMC MICROWAVE CABLE ASSEMBLY INSTRUCTIONS

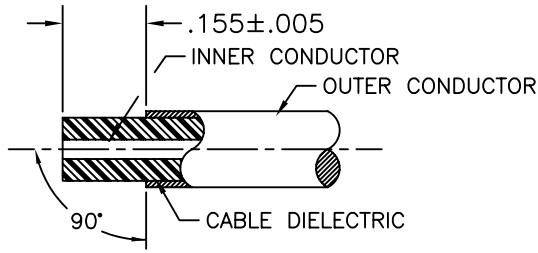

1.0 PREPARATION OF CABLE:

- 1.1 TRIM CABLES OUTER CONDUCTOR TO DIMENSIONS SHOWN. THE CABLES OUTER CONDUCTOR SHOULD BE 90° FROM CENTERLINE. CARE SHOULD BE TAKEN NOT TO NICK CABLE DIELECTRIC OR INNER CONDUCTOR DURING THIS OPERATION.
- 1.2 INSPECT CABLE PREPARATION. REMOVE BURRS & SHARP EDGES FROM OUTER CONDUCTOR WITH SCOTCH BRITE.

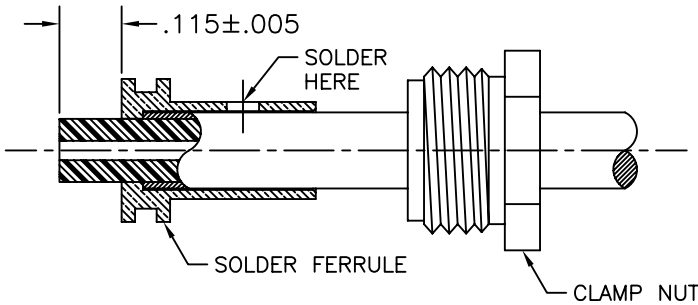

2.0 SOLDERING OF FERRULE TO CABLE OUTER CONDUCTOR:

- 2.1 SLIDE CLAMP NUT ON CABLE AS SHOWN.
- 2.2 TIN OUTER CONDUCTOR OF CABLE. HEAT SOLDER FERRULE AND SLIDE IT OVER CABLE UNTIL IT BOTTOMS COMPLETELY ON CABLE SHOULDER (OUTER CONDUCTOR).
- 2.3 USING A RESISTIVE SOLDERING IRON, SOLDER FERRULE AS SHOWN USING 60/40 SOLDER.
- 2.4 INSPECT & REMOVE EXCESS SOLDER AND CLEAN WITH SOLVENT (ALCOHOL).

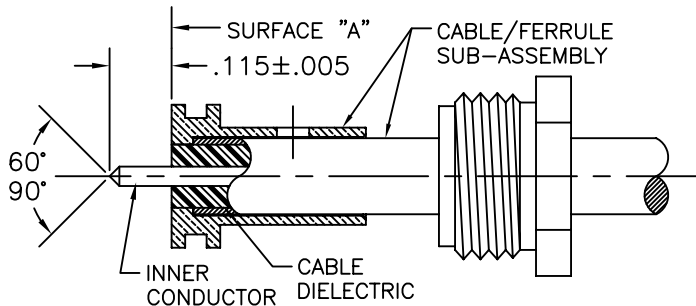

3.0 PREPARATION OF CABLE INNER CONDUCTOR:

- 3.1 TRIM DIELECTRIC FLUSH TO SURFACE "A", CARE SHOULD BE TAKEN NOT TO NICK INNER CONDUCTOR DURING THIS OPERATION.
- 3.2 FILE BLUNT END OF CABLE INNER CONDUCTOR TO A 60°/90° CONE.
- 3.3 INSPECT CABLE PREPARATION.

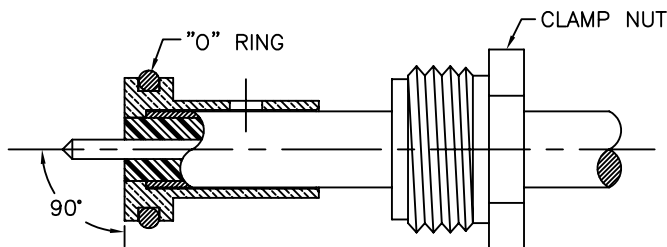

4.0 INSTALLATION OF CABLE/FERRULE SUB-ASSEMBLY:

- 4.1 PLACE "O" RING IN FERRULE GROOVE AS SHOWN.
- 4.2 PLACE CABLE / FERRULE SUB-ASSEMBLY INTO THE BACK OF CONNECTOR SUB-ASSEMBLY BODY. CARE SHOULD BE TAKEN NOT TO BEND OR DAMAGE INNER CONDUCTOR OR CENTER CONTACT OF CONNECTOR.
- 4.3 SLIDE CLAMP NUT OVER CABLE TO BODY & TIGHTEN CLAMP NUT TO 15 INCH-POUNDS.

4.0 ENLARGED VIEW OF CABLE ASSEMBLY:

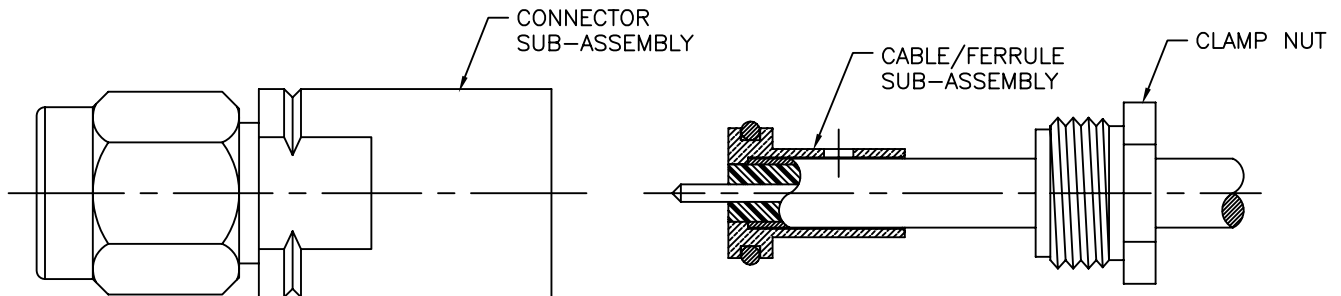

DWG NO.

200-32-20-410

SGMC MICROWAVE
www.sgmcmicrowave.com

TOOLS REQUIRED:

1. RESISTANCE SOLDERING MACHINE.
2. FLUX, SOLDER POT, 60/40 SOLDER.
3. RAZOR BLADES.
4. SCOTCH BRITE.
5. SOLVENT (ISOPROPYL ALCOHOL).

TITLE:

2.4mm MALE TO
.141 SEMI-RIGID CABLE
(Solder Clamp)

SCALE: NTS CAGE CODE: 1UYM4 SIZE: A

SHEET: 1 OF 1 DRAWN: LRH II APPR:

REVISIONS

LTR:	DESCRIPTION: (ECN#)	DATE:
--	DWG. RELEASED	05/18/05

"PROPRIETARY INFORMATION"