

SGMC MICROWAVE CABLE ASSEMBLY INSTRUCTIONS

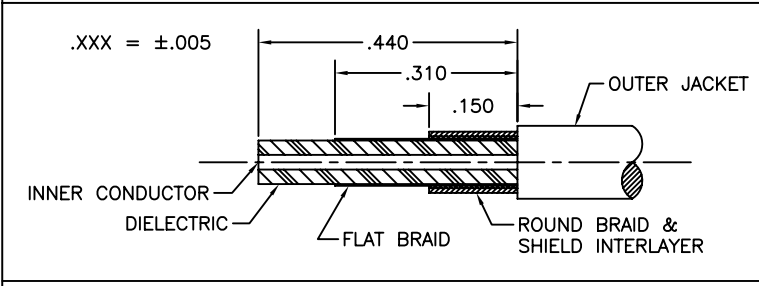

1.0 PREPARATION OF CABLE:

- 1.1 TRIM CABLE TO DIMENSIONS SHOWN. THE CABLES OUTER JACKET, INNER CONDUCTOR, & INNER BRAIDS SHOULD BE 90° FROM CENTERLINE. CARE SHOULD BE TAKEN NOT TO NICK CABLE DIELECTRIC, INNER CONDUCTOR, OR INNER BRAIDS DURING THIS OPERATION.
- 1.2 INSPECT CABLE PREPARATION TO DIMENSIONS SHOWN.

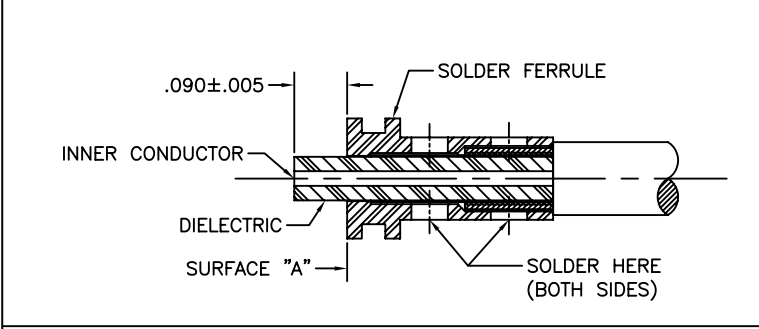

2.0 SOLDERING OF FERRULE TO CABLE OUTER CONDUCTOR:

- 2.1 SLIDE CALMP NUT ONTO CABLE AS SHOWN BELOW IN STEP 4.0 (ENLARGED VIEW).
- 2.2 TIN INNER BRAIDS OF CABLE. HEAT SOLDER FERRULE AND SLIDE IT OVER CABLE UNTIL IT BOTTOMS COMPLETELY ON CABLE SHOULDER (OUTER JACKET).
- 2.3 USING A RESISTIVE SOLDERING IRON, SOLDER FERRULE AS SHOWN USING 60/40 SOLDER (BOTH SIDES).
- 2.4 INSPECT & REMOVE EXCESS SOLDER AND CLEAN WITH SOLVENT (ALCOHOL).

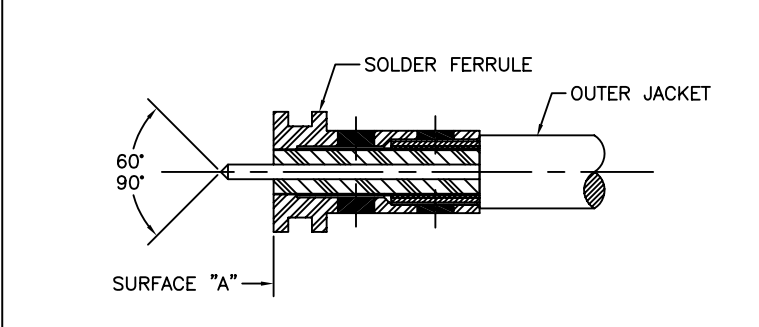

3.0 PREPARATION OF CABLE INNER CONDUCTOR:

- 3.1 TRIM DIELECTRIC FLUSH TO SURFACE "A". CARE SHOULD BE TAKEN NOT TO NICK INNER CONDUCTOR DURING THIS OPERATION.
- 3.2 FILE BLUNT END OF CABLE INNER CONDUCTOR TO A 60°/90° CONE.
- 3.3 INSPECT CABLE PREPARATION

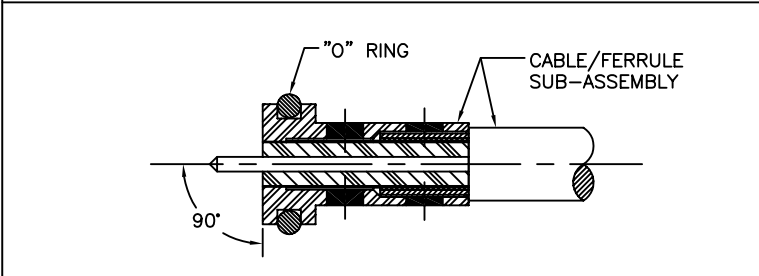

4.0 INSTALLATION OF CABLE/FERRULE SUB-ASSEMBLY:

- 4.1 PLACE "O" RING IN FERRULE GROOVE AS SHOWN.
- 4.2 PLACE CABLE / FERRULE SUB-ASSEMBLY INTO THE BACK OF CONNECTOR SUB-ASSEMBLY BODY. CARE SHOULD BE TAKEN NOT TO BEND OR DAMAGE INNER CONDUCTOR OR CENTER CONTACT OF CONNECTOR.
- 4.3 SLIDE CLAMP NUT OVER CABLE TO BODY & TIGHTEN CLAMP NUT TO 15 INCH-POUNDS.

4.0 ENLARGED VIEW OF CABLE ASSEMBLY:

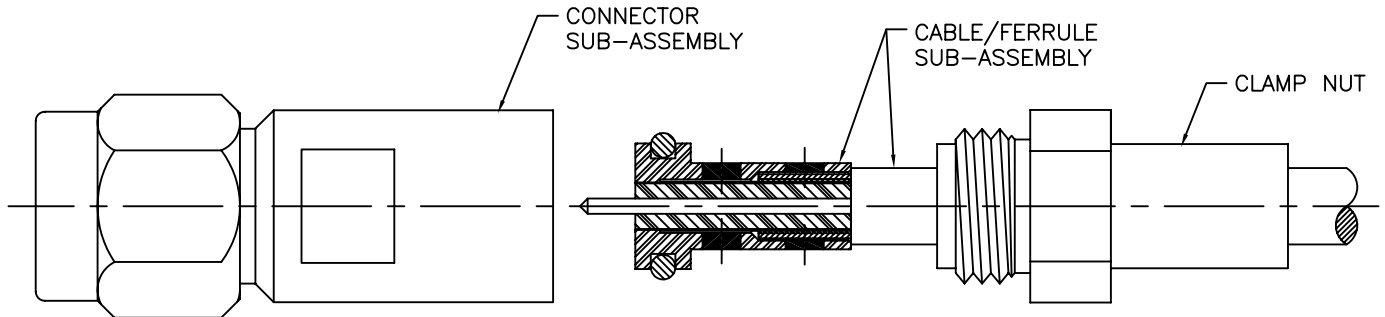

DWG NO. **200-36-20-020**

SGMC MICROWAVE
www.sgmcmicrowave.com

TOOLS REQUIRED:

1. RESISTANCE SOLDERING MACHINE.
2. FLUX, SOLDER POT, 60/40 SOLDER.
3. RAZOR BLADES.
4. SCOTCH BRITE.
5. SOLVENT (ISOPROPYL ALCOHOL).

TITLE:
**3.5mm MALE TO
HP120 LOW LOSS
CABLE (Solder Clamp)**

SCALE: NTS	CAGE CODE: 1UYM4	SIZE: A
SHEET: 1 OF 1	DRAWN: LRH II	APPR:
REVISIONS		
LTR: DESCRIPTION: (ECN#)	DATE:	
-- DWG. RELEASED	07/27/04	
A ECN. #1138	10/21/04	

"PROPRIETARY INFORMATION"