

DWG NO.

200-37-20-240

NOTES:

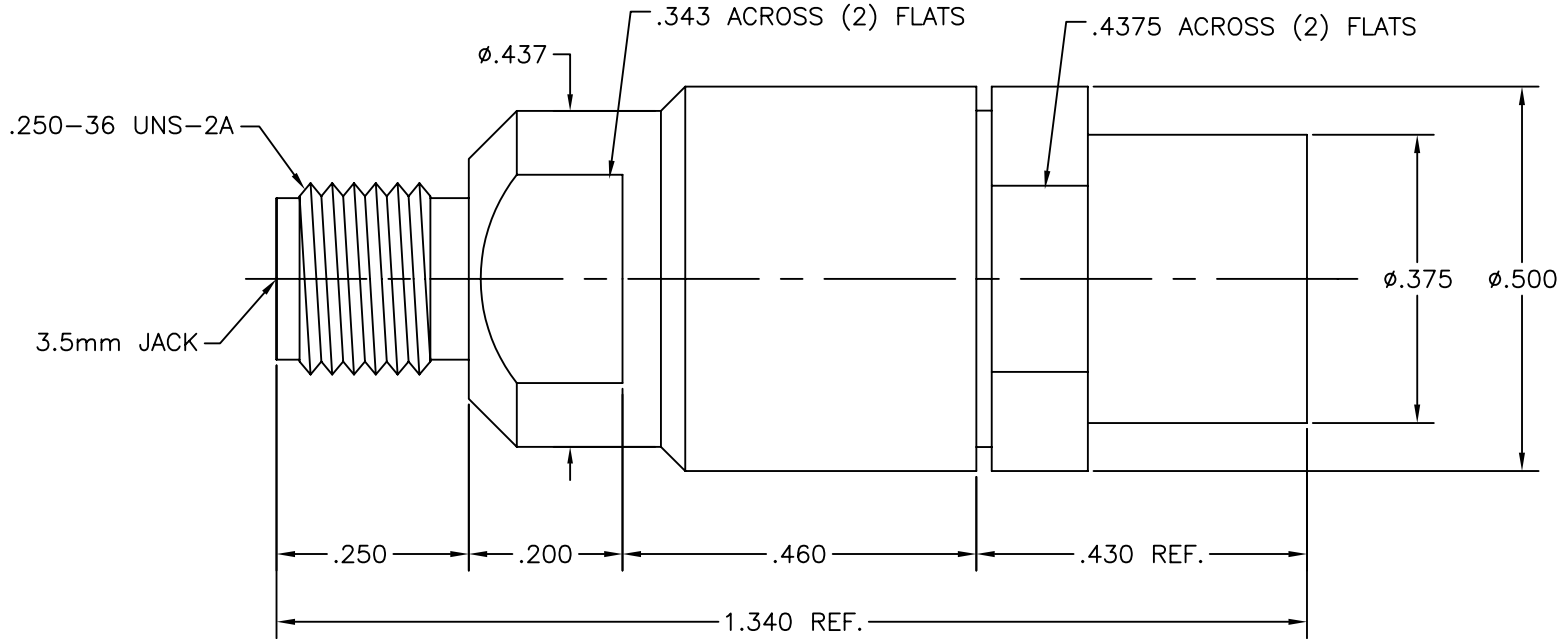

DWG NO. 200-37-20-240

SGMC MICROWAVE
www.sgmcmicrowave.com

USED ON:
"OUTLINE DRAWING"

REVISIONS

TITLE:
**3.5mm FEMALE TO
I.W. 2303 CABLE
(Solder Clamp)**

SCALE: NTS CAGE CODE: 1UYM4 SIZE: A SHEET: 1 OF 1 DRAWN: LRH || APPR:

LTR:	DESCRIPTION: (ECN#)	DATE:
--	DWG. RELEASED	04/29/04
A	ECN. #1122	04/29/04

- UNLESS OTHERWISE SPECIFIED:
1. REMOVE ALL BURRS.
 2. ALL DIMENSIONS ARE AFTER PLATING.
 3. BREAK ALL CORNERS & EDGES .005 R. MAX.
 4. CHAMFER 1st & LAST THREADS 45°.
 5. DIAMETERS ON COMMON CENTERS SHALL BE CONCENTRIC WITHIN .002 T.I.R.
 6. ALL SURFACES FINISHED TO 32√.

TOLERANCES
ALL DIMENSIONS
ARE IN INCHES
"DECIMALS"
.X ±.030
.XX ±.010
.XXX ±.005

FINISH:

MATERIAL:

"PROPRIETARY INFORMATION" THE INFORMATION WITHIN THIS DRAWING IS PROPRIETARY AND SHALL NOT BE USED OR DISCLOSED WITHOUT PRIOR WRITTEN PERMISSION FROM (SGMC) SGMC MICROWAVE.