

SGMC MICROWAVE CABLE ASSEMBLY INSTRUCTIONS

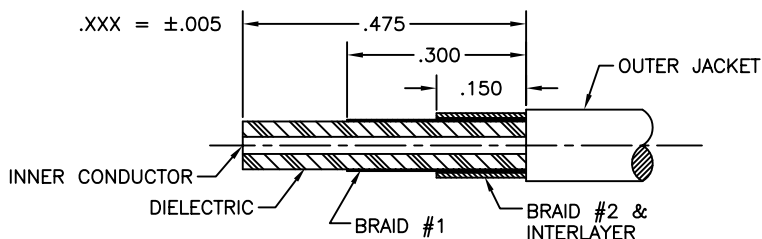

1.0 PREPARATION OF CABLE:

- 1.1 TRIM CABLE TO DIMENSIONS SHOWN. THE CABLES OUTER JACKET, INNER CONDUCTOR, & INNER BRAIDS SHOULD BE 90° FROM CENTERLINE. CARE SHOULD BE TAKEN NOT TO NICK CABLE DIELECTRIC, INNER CONDUCTOR, OR INNER BRAIDS DURING THIS OPERATION.
- 1.2 INSPECT CABLE PREPARATION TO DIMENSIONS SHOWN.

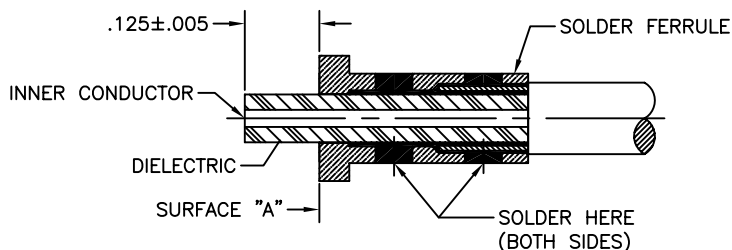

2.0 SOLDERING OF FERRULE TO CABLE OUTER CONDUCTOR:

- 2.1 SLIDE CLAMP NUT ONTO CABLE AS SHOWN BELOW IN STEP 4.0 (ENLARGED VIEW).
- 2.2 TIN INNER BRAIDS OF CABLE. HEAT SOLDER FERRULE AND SLIDE IT OVER CABLE UNTIL IT BOTTOMS COMPLETELY ON CABLE SHOULDER (OUTER JACKET).
- 2.3 USING A RESISTIVE SOLDERING IRON, SOLDER FERRULE AS SHOWN USING 60/40 SOLDER (BOTH SIDES).
- 2.4 INSPECT & REMOVE EXCESS SOLDER AND CLEAN WITH SOLVENT (ALCOHOL).

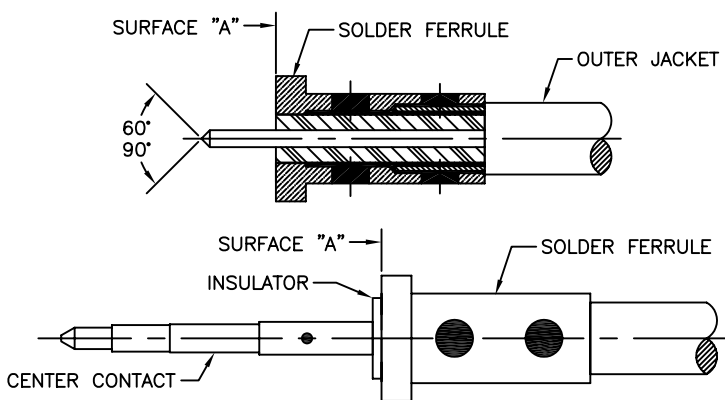

3.0 PREPARATION OF CABLE INNER CONDUCTOR & CONTACT:

- 3.1 TRIM DIELECTRIC FLUSH TO SURFACE "A". CARE SHOULD BE TAKEN NOT TO NICK INNER CONDUCTOR DURING THIS OPERATION.
- 3.2 FILE BLUNT END OF CABLE INNER CONDUCTOR TO A 60°/90° CONE.
- 3.3 INSPECT CABLE PREPARATION.
- 3.4 PLACE INSULATOR ON CENTER CONDUCTOR OF CABLE RESTING FIRMLY AGAINST SURFACE "A" AS SHOWN.
- 3.5 TIN INNER CONDUCTOR OF CABLE. HEAT CONTACT AND SLIDE IT OVER INNER CONDUCTOR OF CABLE TO REST FIRMLY AGAINST INSULATOR.
- 3.6 USING 60/40 SOLDER, SOLDER CONTACT AS SHOWN.
- 3.7 INSPECT & REMOVE EXCESS SOLDER. CLEAN WITH SOLVENT

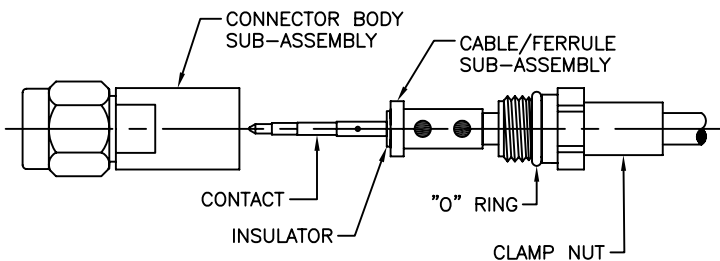

4.0 INSTALLATION OF CABLE/FERRULE SUB-ASSEMBLY:

- 4.1 INSERT CABLE/FERRULE INTO THE BACK END OF CONNECTOR BODY UNTIL IT BOTTOMS AGAINST THE INSULATOR INSIDE THE BODY. CARE SHOULD BE TAKEN NOT TO BEND OR DAMAGE INNER CONDUCTOR OR CENTER CONTACT OF CONNECTOR.
- 4.2 SLIDE CLAMP NUT OVER CABLE TO BODY & TIGHTEN CLAMP NUT TO 15 INCH-POUNDS.
- 4.3 INSPECT SMA INTERFACE PER MIL-STD-348. DIELECTRIC = .000 / -.010" (FLUSH TO .010" BELOW REF. PLANE) CONTACT = .000 / -.010" (FLUSH TO .010" BELOW REF. PLANE)

4.0 ENLARGED VIEW OF CABLE ASSEMBLY:

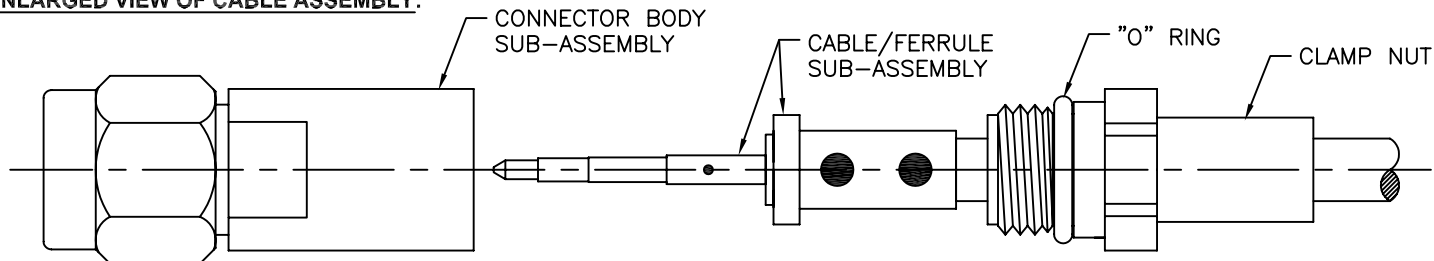

DWG NO.

200-50-20-200

TITLE:

SMA MALE TO
LL120 CABLE
(Solder Clamp)

SGMC MICROWAVE
www.sgmcmicrowave.com

SCALE: NTS CAGE CODE: 1UYM4 SIZE: A

SHEET: 1 OF 1 DRAWN: LRH II APPR:

REVISIONS

LTR:	DESCRIPTION: (ECN#)	DATE:
--	DWG. RELEASED	12/20/04

TOOLS REQUIRED:

1. RESISTANCE SOLDERING MACHINE.
2. FLUX, SOLDER POT, 60/40 SOLDER.
3. RAZOR BLADES.
4. SOLVENT (ISOPROPYL ALCOHOL).

"PROPRIETARY INFORMATION"