

DWG NO.

311-34-12-000

NOTES:

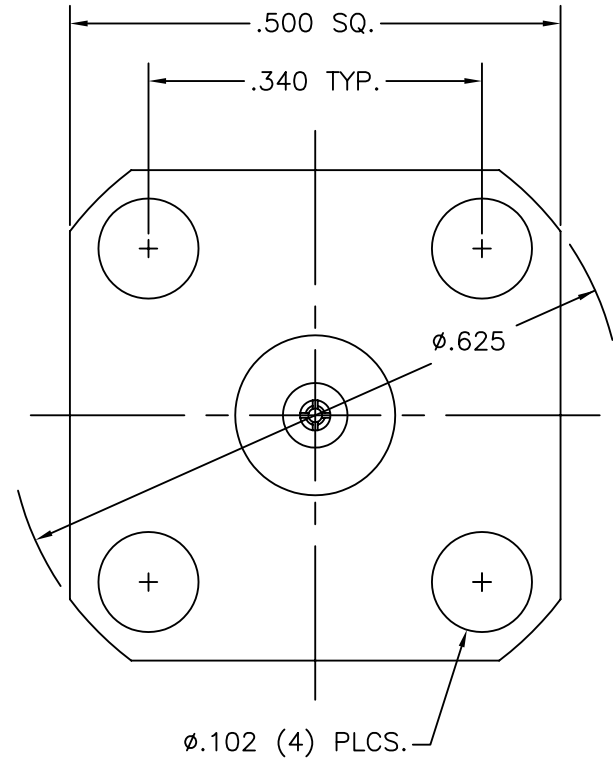
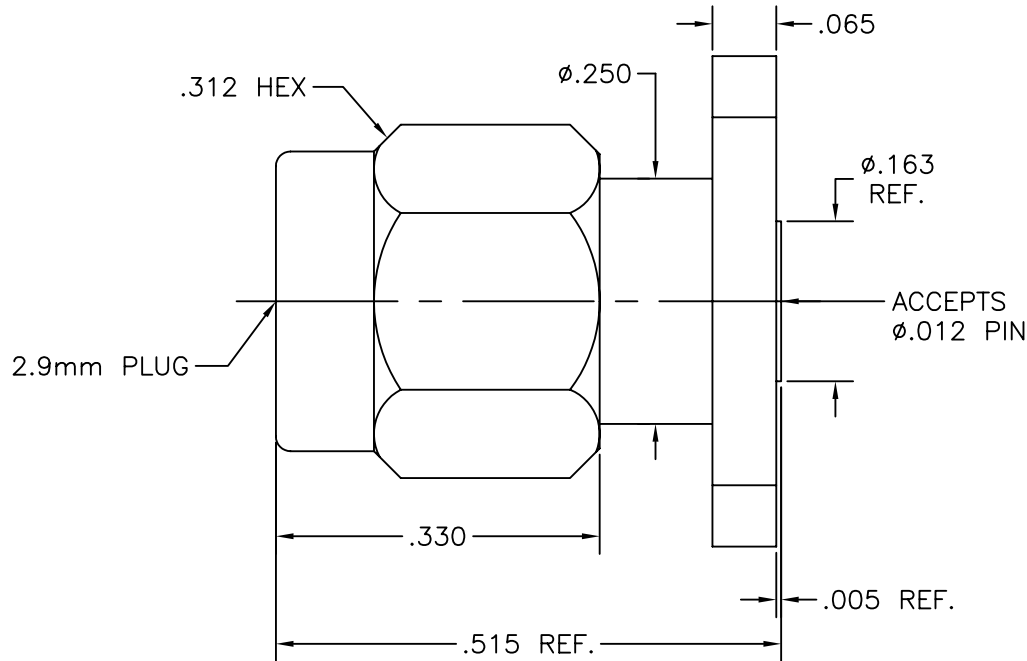

DWG NO.

311-34-12-000

SGMC MICROWAVE
www.sgmcmicrowave.com

USED ON:

"OUTLINE DRAWING"

REVISIONS

LTR:	DESCRIPTION: (ECN#)	DATE:
--	DWG. RELEASED	07/17/01

TITLE:

**2.9mm MALE
(4) HOLE FLANGE
RECEPTACLE**

SCALE: NTS

CAGE CODE: 1UYM4

SIZE: A

SHEET: 1 OF 1

DRAWN: LRH ||

APPR:

UNLESS OTHERWISE SPECIFIED:

1. REMOVE ALL BURRS.
2. ALL DIMENSIONS ARE AFTER PLATING.
3. BREAK ALL CORNERS & EDGES .005 R. MAX.
4. CHAMFER 1st & LAST THREADS 45°.
5. DIAMETERS ON COMMON CENTERS SHALL BE CONCENTRIC WITHIN .002 T.I.R.
6. ALL SURFACES FINISHED TO 32V.

TOLERANCES
ALL DIMENSIONS
ARE IN INCHES

"DECIMALS"

.X ±.030
.XX ±.010
.XXX ±.005

FINISH:

MATERIAL:

"PROPRIETARY INFORMATION" THE INFORMATION WITHIN THIS DRAWING IS PROPRIETARY AND SHALL NOT BE USED OR DISCLOSED WITHOUT PRIOR WRITTEN PERMISSION FROM (SGMC) SGMC MICROWAVE.