

DWG NO.

350-21-00-004

NOTES: 1. BODY: 360 BRASS (NICKEL PLATE)
2. CONTACT: BECU (GOLD PLATE)

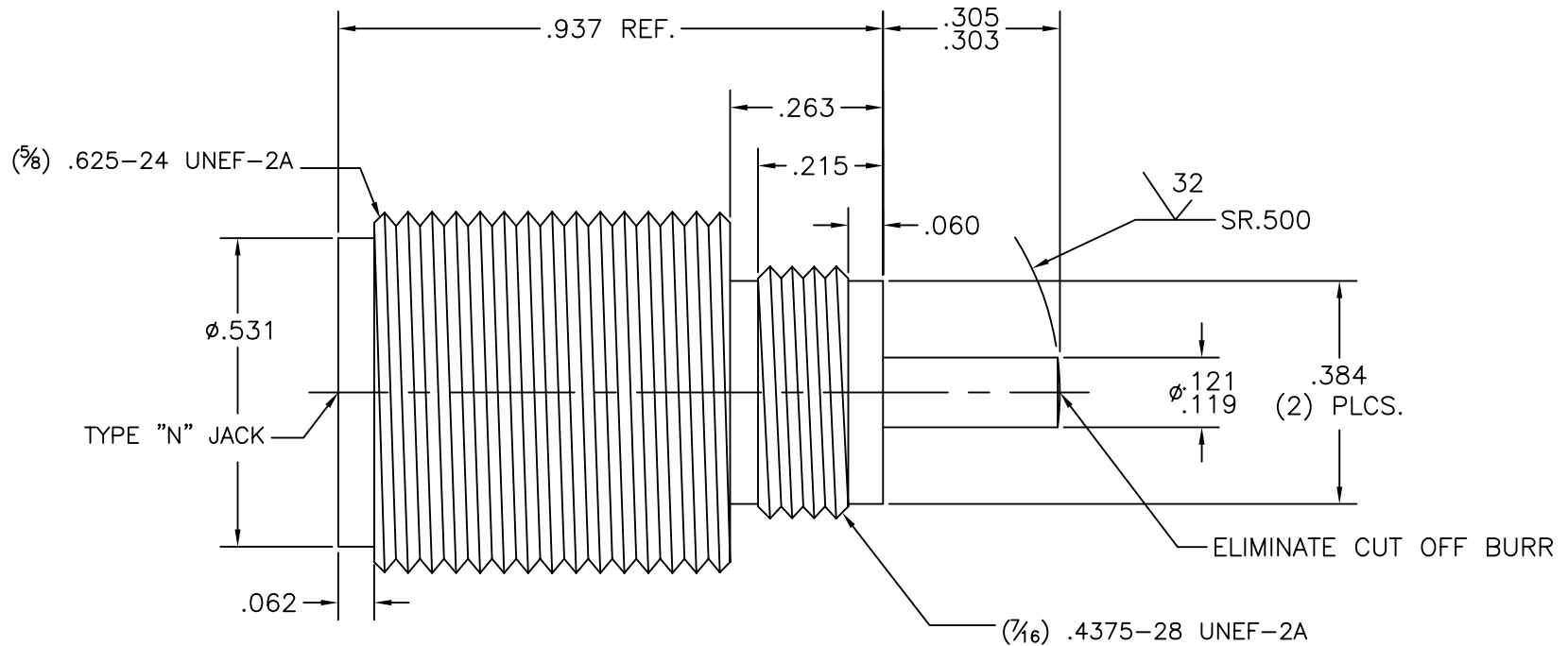

DWG NO. **350-21-00-004**

SGMC MICROWAVE
www.sgmcmicrowave.com

USED ON: **"OUTLINE DRAWING"**

REVISIONS		
LTR:	DESCRIPTION: (ECN#)	DATE:
--	DWG. RELEASED	08/11/10

TITLE:
**TYPE "N" FEMALE
SWITCH CONNECTOR
(Straight Terminal)**

SCALE: NTS CAGE CODE: 1UYM4 SIZE: A

SHEET: 1 OF 1 DRAWN: LRH || APPR:

- UNLESS OTHERWISE SPECIFIED:
1. REMOVE ALL BURRS.
 2. ALL DIMENSIONS ARE AFTER PLATING.
 3. BREAK ALL CORNERS & EDGES .005 R. MAX.
 4. CHAMFER 1st & LAST THREADS 45°.
 5. DIAMETERS ON COMMON CENTERS SHALL BE CONCENTRIC WITHIN .002 T.I.R.
 6. ALL SURFACES FINISHED TO 32√.

TOLERANCES
ALL DIMENSIONS
ARE IN INCHES
"DECIMALS"

.X	±.030
.XX	±.010
.XXX	±.005

FINISH:

MATERIAL:

"PROPRIETARY INFORMATION" THE INFORMATION WITHIN THIS DRAWING IS PROPRIETARY AND SHALL NOT BE USED OR DISCLOSED WITHOUT PRIOR WRITTEN PERMISSION FROM (SGMC) SGMC MICROWAVE.